



Nozzles and Accessories for Compressed Air



A wide range of
noise-reduced nozzles



Compressed Air can Make the Process More Efficient

In many industries compressed air is a vital aid for drying, cooling and transporting, blowing-off and cleaning, loosening and mixing and assists thereby the economical realization of processes. The range of applications has not reached its limit. In all these applications two aspects should be taken into consideration: Generating compressed air requires money and the high-frequency noise, this occurs mainly at high pressures and by using single orifice nozzles and can damage hearing. Therefore it is necessary to use compressed air as economically as possible and to use modern technics of low noise.

Lechler has combined its total know-how of nozzle technology, the practical experience concerning applications and newest trends of research and has provided a special offer to this subject. Should it not be possible for you to find a solution for a special case within this wide range, please contact our specialists.

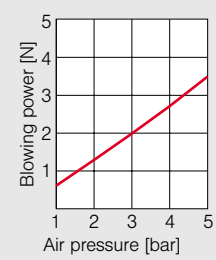
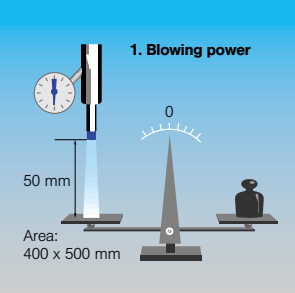
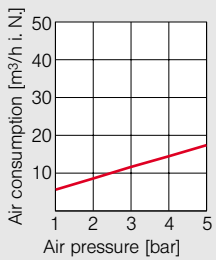
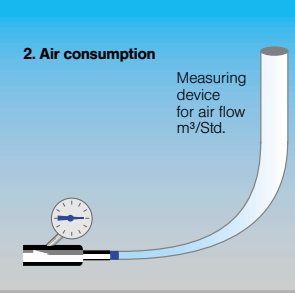
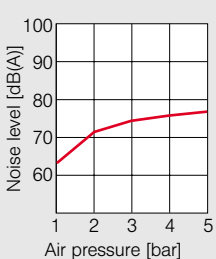
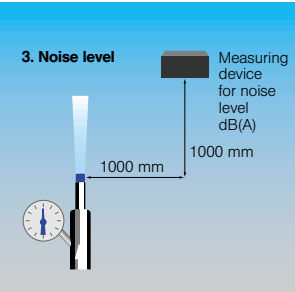
Example for measuring	Measuring method
	
	
	

Blowing power, air consumption and noise level are the three decisive criterions for the selection of air nozzles. In order to reach comparable values Lechler uses measuring methods, which are typical in the industry.

Modern Nozzle Technics for More Efficiency and Less Noise.

By the development of new **multiple spray nozzles** with specially formed nozzle orifices, the noise causing turbulences at the air exit have been considerably reduced; at the same time an improvement of the efficiency was reached by the nozzle construction. Thus it is possible to reduce the air pressure -and also the air consumption - but maintain a constant blowing power.

This positive effect was reached mainly by dividing the air stream into smaller air streams. Hereby the incoming compressed air is led evenly into air channels, which are favourably arranged with regard to streaming. The result is a particularly even and powerful total air stream.

The advantages for practical use are convincing:

More comfortable working conditions

by reducing the noise level by up to 12 dB.

► This corresponds to a reduction by a half of the noise for the human ear.

Lower energy costs

by lower working-air pressure at the same blowing power.

► Thereby the air consumption will be considerably reduced.

Higher capacity

by better blowing power from larger distances and by an evenly directed air stream.

► Thereby the efficiency will be considerably increased. This new technology of using compressed air offers new areas for application.

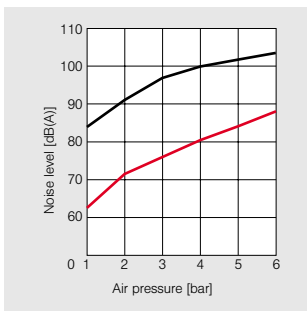
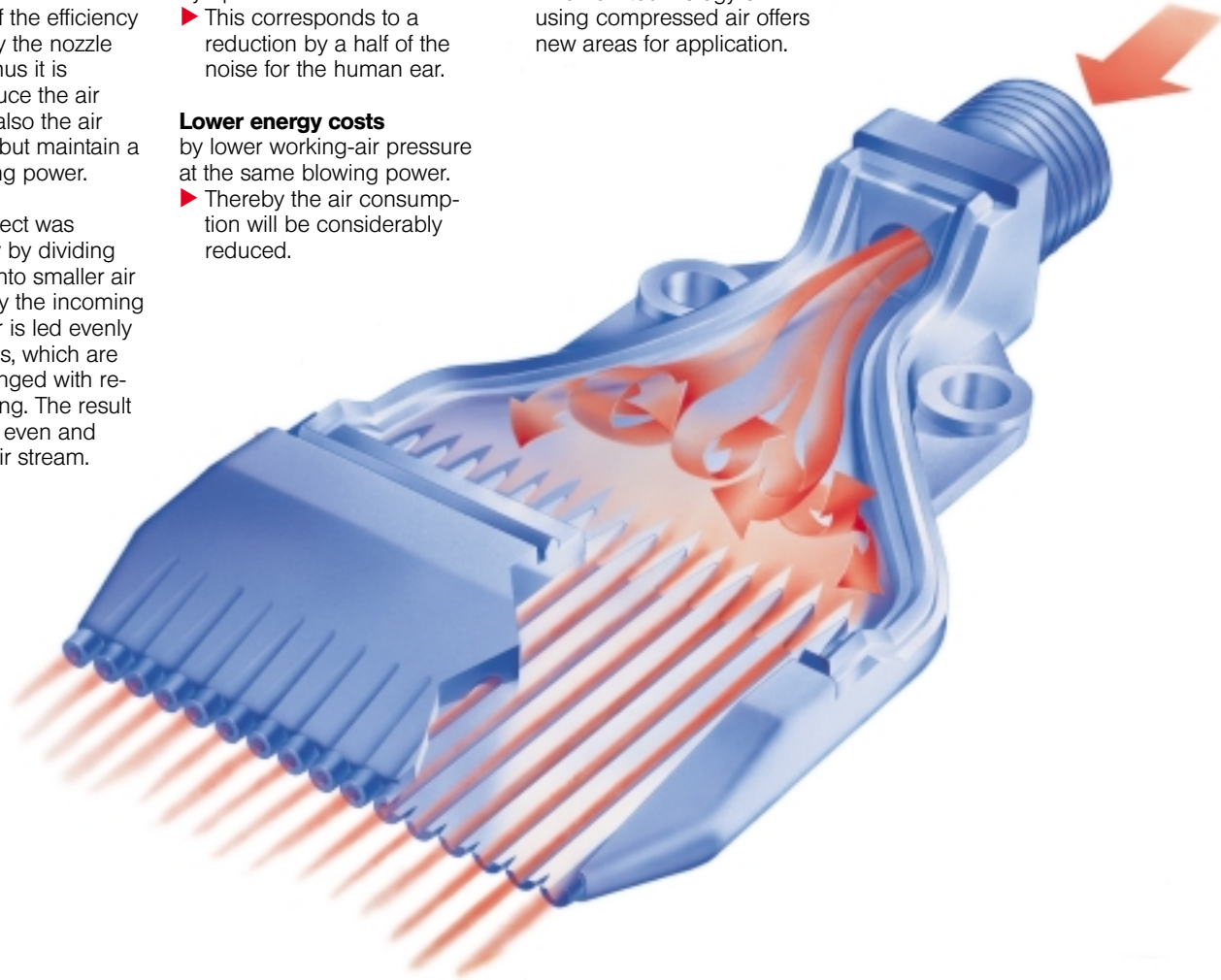

— Lechler multiple spray nozzle
— Conventional nozzle

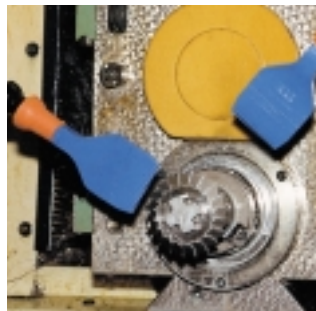

The new Lechler compressed air nozzles have already proven successful in practice in many operations.



Whisperblast Multiple Spray Nozzles

Low-noise flat jet nozzles

Standard versions
for universal applications

Multiple spray flat jet nozzle series 600.130 / 600.283

- Powerful air stream, directed on the surface
- Low noise level
- Low air consumption
- Standard nozzle with a big variety of applications
- Aluminium version for high mechanical/thermal stress

Applications:

Blowing-off, cleaning, drying, cooling, transporting.



600.130.56 (POM)



600.283.42 (aluminium)



600.130.56.01 with accessories

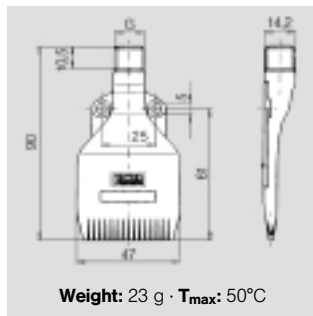

Weight: 23 g · T_{max}: 50°C

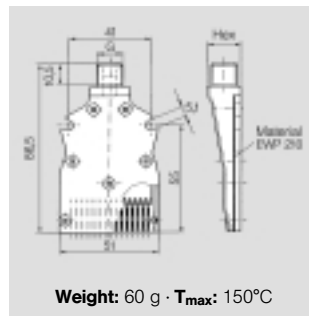

Weight: 60 g · T_{max}: 150°C

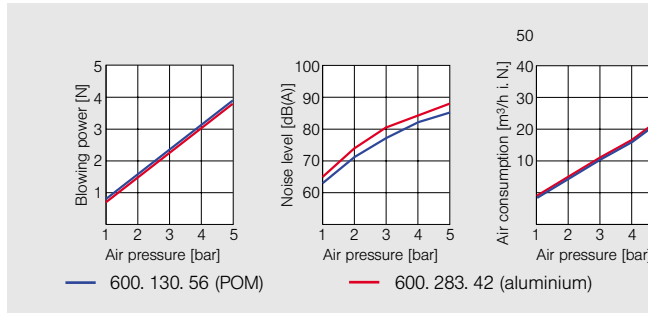
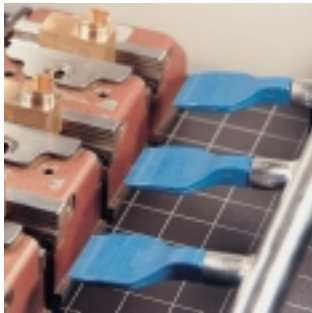

Blowing-off of the sprue from the permanent mould, illustration: Oetinger.



Nozzle row see page 12

Ordering no.		Thread connection G	Accessories
Type	Code		
600.130.56 (material: POM)	BC	1/4 NPT	
	AC	1/4 BSPP	
	02	1/4 BSPP	Plug
	01	1/4 BSPP	Plug Hose nipple (D = 8 mm), Clamping piece, steel (L = 85 mm)
600.283.42 (material: aluminium)	BC	1/4 NPT	
	AC	1/4 BSPP	

Example for ordering:	Type	+	Code	=	Ordering no.
	600.130.56	+	AC	=	600.130.56.AC



Whisperblast Multiple Spray Nozzles

Low-noise flat jet nozzles

Special versions
for special applications

Mini-flat jet nozzle type 600.382.30.AE

■ Exceptionally low air consumption

Weight: 35 g · **T_{max}:** 90°C

V_{Air}: 15 m³/h at 2 bar

Connection: 3/8 BSPP

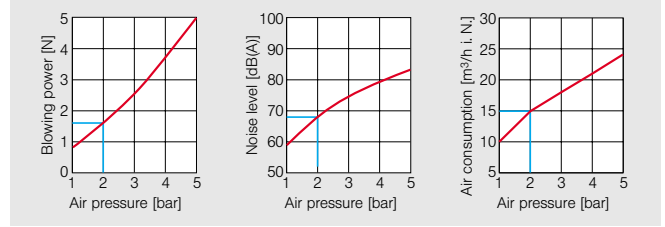

Intensive-flat jet nozzle type 600.383.30.AE

■ Exceptionally high blowing power

Weight: 36 g · **T_{max}:** 90°C

V_{Air}: 25 m³/h at 2 bar

Connection: 3/8 BSPP

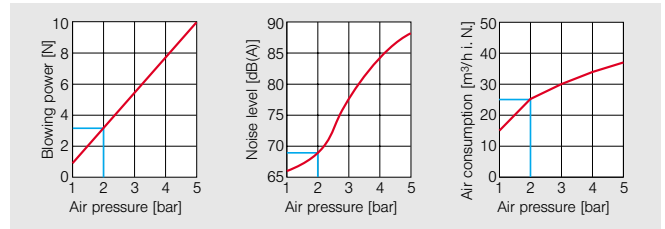

Compact-flat jet nozzle type 600.386.01.AE

■ Exceptionally short form for narrow positions

Weight: 38 g · **T_{max}:** 90°C

V_{Air}: 20 m³/h at 2 bar

Connection: 3/8 BSPP

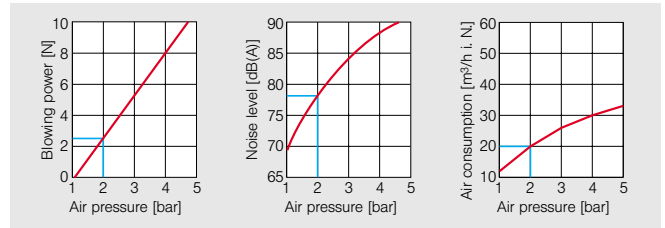

Maxi-flat jet nozzle type 600.385.30.AL

■ Suitable for low-noise blowing of big air quantities

Weight: 155 g · **T_{max}:** 90°C

V_{Air}: 51 m³/h at 2 bar

Connection: 3/4 BSPP

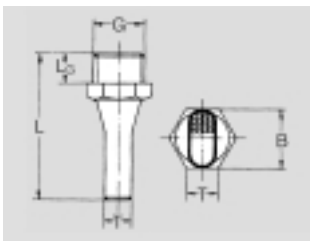
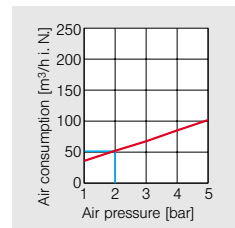
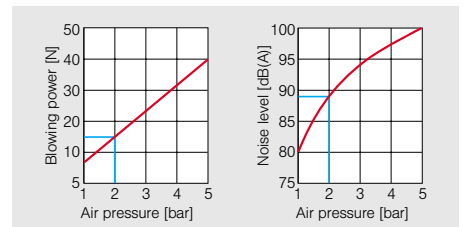

Ordering no.	Material	G BSPP	L [mm]	L _G [mm]	S [mm]	T [mm]
600.382.30.AE	Brass/PVC	3/8	100	10	21,5	4,5
600.383.30.AE	Brass/PVC	3/8	100	10	21,0	6,0
600.386.01.AE	Steel/PVC	3/8	50	10	16,5	8,5
600.385.30.AL	Brass/PVC	3/4	120	-	43,0	9,0



Whisperblast Multiple Spray Nozzles

Low-noise round jet nozzles

Multiple round jet nozzle series 600.326

- Powerful, focused impinging air stream
- Low noise level
- Low air consumption
- Standard nozzle with big varieties of application
- Mainly suitable in connection with an usual hand held air gun

Applications:

Precise blowing-off, drying and cooling.

Zinc-version is not for use with steam or in steam atmosphere.



600.326.5K (ABS)



600.326.3W (Zinc)

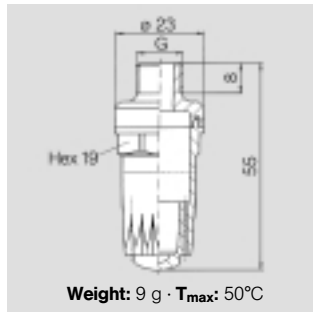

Weight: 9 g · T_{max}: 50°C

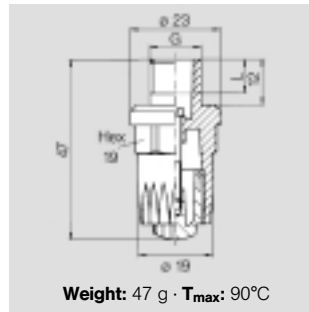

Weight: 47 g · T_{max}: 90°C



Type 600.326.5K.HG
in connection with typical compressed air gun

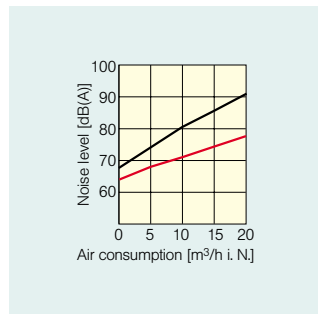
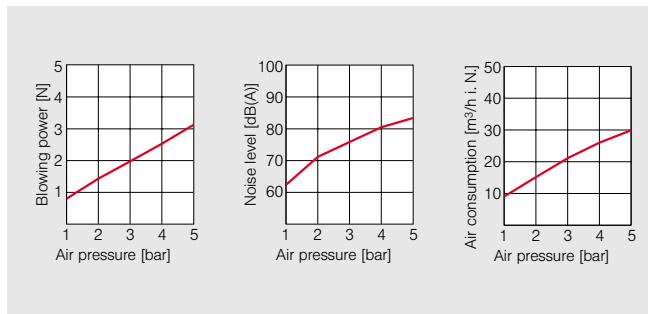

— Lechler 600.326
— Single orifice nozzle

Reduction of the noise level of up to 12 dB (A) in comparison to single orifice nozzles

▶ **Reduction of noise up to 60%.**

Ordering no.		Thread connection G
Type	Code	
600.326.5K (Material: ABS)	BA	1/8 NPT
	BC	1/4 NPT
	AC	1/4 BSPP
	HG	M 12 x 1,25
600.326.3W (Material: Zinc)	AC	1/4 BSPP
	HG	M 12 x 1,25



Example for ordering: Type 600.326.5K + Code AC = Ordering no. 600.326.5K.AC



Whisperblast Multiple Spray Nozzles

Low-noise round jet nozzles

Mini-multiple round jet nozzles series 600.388

- Particularly high blowing
- Compact form
- Mainly suitable for positions where access is limited and also for blowing-out blind holes

Material: Brass/POM

Weight: 12 g · T_{max}: 50°C

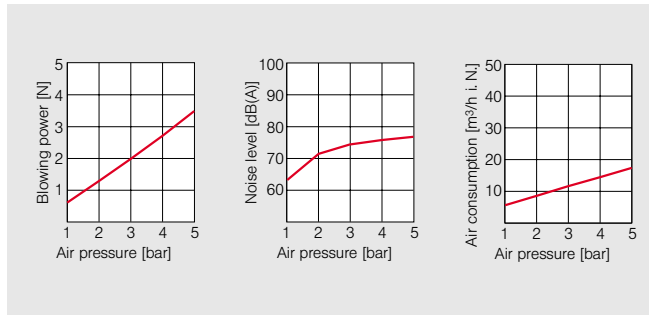
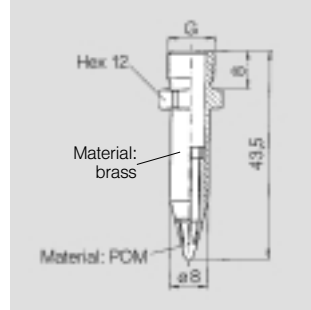

Ordering no.		Thread connection G
Type	Code	
600.388.30	AA	1/8 BSPP
(Material: Brass/POM)	HG	M 12 x 1,25

Example for ordering: Type 600.388.30 + Code + AA = Ordering no. = 600.388.30.AA

Maxi-multiple round jet nozzle type 600.387.30.AH

- Particularly high blowing power, even for long distances

Material: Brass/PVC

Weight: 100 g · T_{max}: 90°C

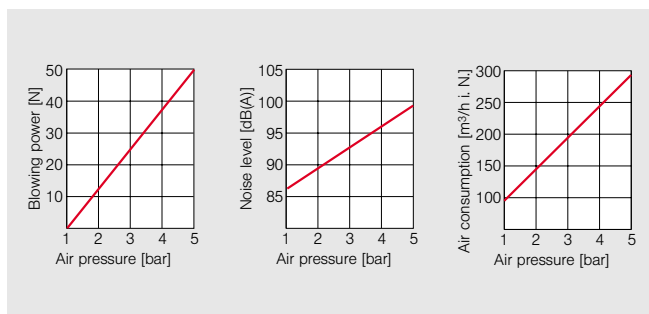
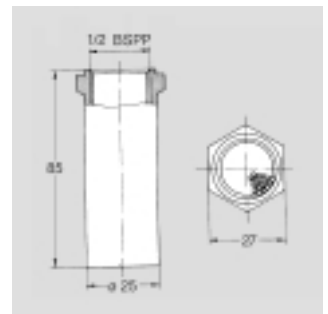



Compressed Air Nozzles for Special Applications

Flat jet slot nozzles

Flat jet slot nozzle for air and saturated steam series 679

- Wide, strong air stream
- Easy, adjustable mounting
- Easy, spray adjustment

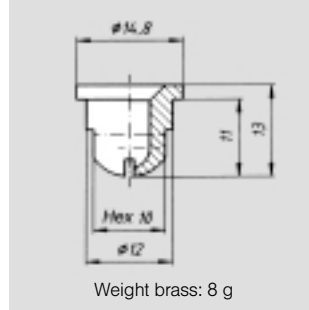

Weight brass: 8 g



Accessories for assembly see p. 11

Ordering no.		A Ø [mm]	V̇ _n Air [m ³ /h i. N.]				Ṁ Saturated steam [kg/h]				
Type	Mat. no.		p [bar]				p [bar]				
	17		30	0,5	2,0	5,0	10,0	0,5	2,0	5,0	10,0
679. 037	-	○	1,2	1,40	2,60	5,40	11,00	0,50	1,50	3,20	6,10
679. 085	○	○	1,3	1,20	3,00	6,00	11,10	0,90	1,90	3,70	6,70
679. 117	○	○	1,5	1,70	3,50	7,80	15,00	0,80	2,30	5,10	9,50
679. 165	○	○	1,8	2,20	5,30	10,70	19,50	1,70	3,30	6,60	11,80
679. 255	○	○	2,1	3,20	7,90	15,70	28,80	2,50	4,90	9,70	17,50
679. 365	○	○	2,8	5,40	13,10	26,20	48,10	4,10	8,20	16,10	29,10
679. 415	○	○	3,6	8,90	21,70	43,30	79,40	6,80	13,60	26,70	48,10
679. 495	○	○	4,3	13,40	32,80	65,60	120,20	10,30	20,60	40,40	72,90

A = equivalent bore diameter

Example **Type** **+** **Material no.** **=** **Ordering no.**
for ordering: **679. 037** **+ 30** **= 679. 037. 30**

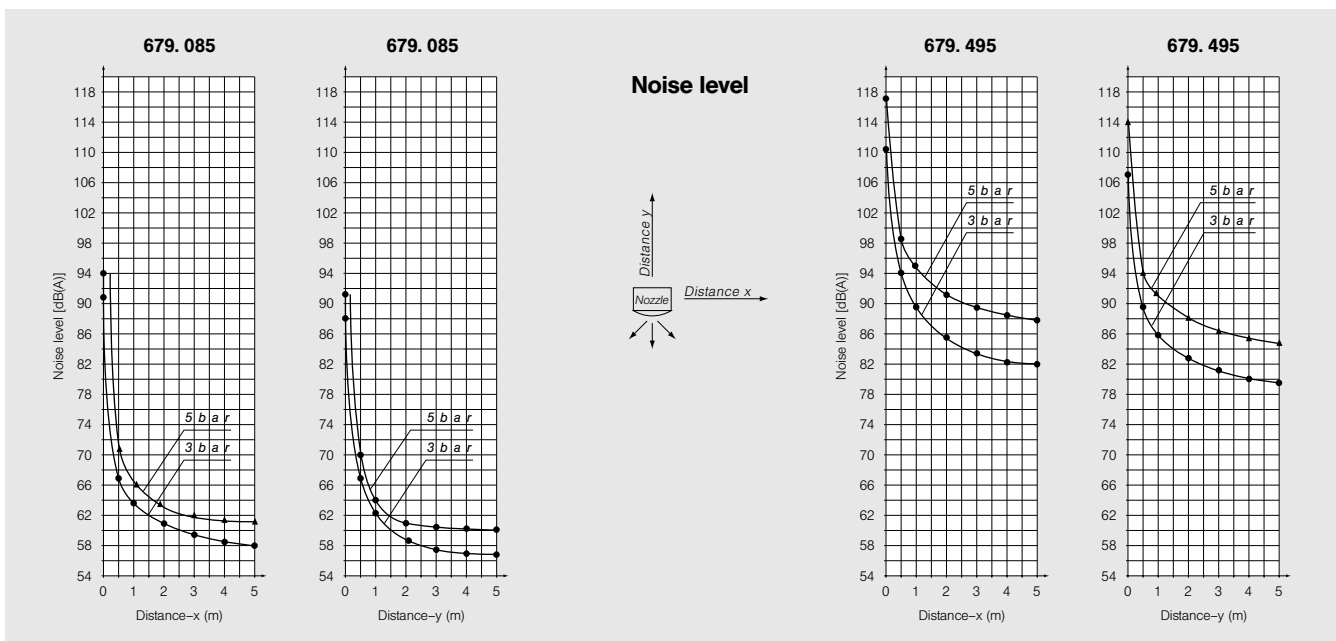



Compressed Air Nozzles for Special Applications

Flat jet tongue type nozzles / Multiple solid jet nozzles

Flat jet tongue type nozzle for air and saturated steam series 686

- Air stream on an extremely wide area
- Suitable for short blowing distances

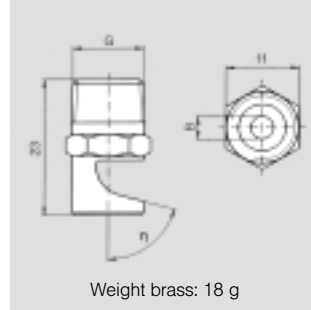

Weight brass: 18 g

Ordering no.			B [mm]	η	V̇ _n Air [m ³ /h i. N.]				Ṁ Saturated steam [kg/h]					
Type	Mat. no.				p [bar]				p [bar]					
	16	30			1,0	2,0	5,0	10,0	1,0	2,0	5,0	10,0		
	1.4305	Brass	1/8											
			CA											
686. 408	○	○	CA	1,0	75°	0,70	1,00	2,10	3,70	0,90	1,30	2,40	4,00	
686. 488	○	○	CA	1,3	75°	1,20	1,70	3,60	6,20	1,40	2,10	3,90	6,50	
686. 528	○	○	CA	1,5	75°	1,60	2,30	4,80	8,40	1,90	2,80	5,20	8,70	
686. 568	○	○	CA	1,7	75°	2,00	3,00	6,30	11,00	2,50	3,70	6,90	11,50	
686. 608	○	○	CA	1,9	75°	2,50	3,70	7,80	13,50	3,10	4,60	8,60	14,30	
686. 688	○	○	CA	2,4	75°	4,00	5,90	12,40	21,50	4,90	7,30	13,60	22,70	
686. 728	○	○	CA	2,7	75°	7,10	10,00	21,20	38,20	5,70	9,20	16,40	29,20	
686. 808	○	○	CA	3,4	75°	11,20	16,00	33,70	60,60	9,00	14,60	26,00	46,30	

B = bore diameter

Multiple solid jet nozzle for air and saturated steam series 540/541

- Even complete air distribution by 40 single bores

Applications:

Steam atomization into liquids, aeration of bulk material, loosening, atomization of gas into acid and neutralizing baths, liquid circulation, acceleration of chemical reactions and processes.

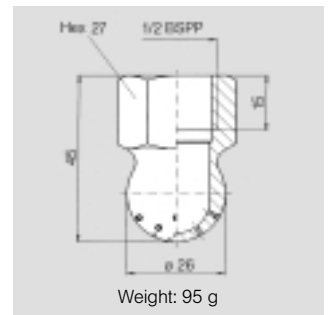
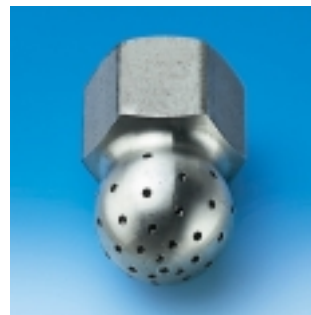

Weight: 95 g

Spray angle	Ordering no.		B Ø [mm]	V̇ _n Air [m ³ /h i. N.]				Ṁ Saturated steam [kg/h]					
	Type	Mat. no.		p [bar]				p [bar]					
		16		1,0	2,0	3,0	5,0	1,0	2,0	3,0	5,0		
		1.4305/303 SS											
			CA										
appr. 240°	540. 909	○	CA	0,8	26,20	39,30	52,50	78,70	21,80	32,00	38,20	58,60	
	540. 989	○	CA	1,0	41,00	61,50	82,00	102,00	34,00	50,00	59,70	91,50	
	541. 109	○	CA	1,5	92,20	138,00	184,00	231,00	76,60	113,00	134,00	206,00	
	541. 189	○	CA	2,0	164,00	246,00	328,00	492,00	136,00	200,00	239,00	366,00	
	541. 239	○	CA	2,3	217,00	325,00	434,00	651,00	180,00	265,00	316,00	484,00	

B = bore diameter

Example for ordering Type + Material no. (+ code) = Ordering no.
686. 408 + 16 (+ CA) = 686. 408. 16. (CA)



Accessories for Flat Jet Slot Nozzles

Clamps

- For flat jet slot nozzles series 679
- Easy fixing of nozzles with nut
- Adjustment of stream without any problems

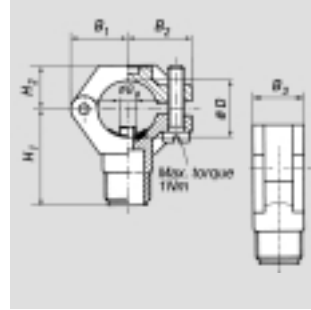

Ordering no.		Dimensions [mm]											Weight (Polyamide)
Type	Material no.			Screw	Pipe ϕ	D ϕ	BR ϕ	B1	B2	B3	H1	H2	
	51	53	5E										
090.003	<input type="radio"/>	<input type="radio"/>	<input type="radio"/>	Material 1.4305	1/2"	20-22,0	6,2	21,2	23,8	18,5	36,5	16,5	20 g
090.013	<input type="radio"/>	<input type="radio"/>	<input type="radio"/>		3/4"	25-27,5	7,8	24,5	26,5	22,0	39,5	17,5	25 g
090.023	<input type="radio"/>	<input type="radio"/>	<input type="radio"/>		1"	32-34,5	10,8	30,0	31,0	22,0	44,0	21,0	32 g

Double nipple

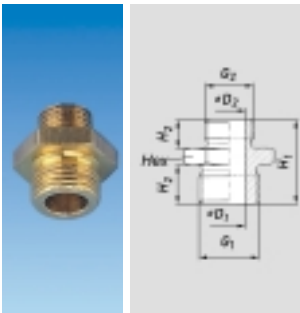

Ordering no.		Dimensions [mm]								Weight (Brass)
Type	Mat. no.		G1 BSPP	G2 BSPP	H1	H2	D1	D2	Hex	
	17	30								
065.215	<input type="radio"/>	<input type="radio"/>	3/8	1/4	25	10	10	7	22	30 g
065.211	<input type="radio"/>	<input type="radio"/>	3/8	3/8	25	10	11,5	-	22	25 g

Nuts

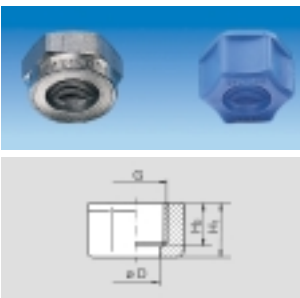

Ordering no.		Material no.					Dimensions [mm]				Weight (brass)
Type	16	17	30	56	5E	G BSPP	H1	H2	D	Hex	
065.200	<input type="radio"/>	<input type="radio"/>	<input type="radio"/>	-	-	3/8	13,0	10,0	12,8	22	25 g
065.200	-	-	-	<input type="radio"/>	<input type="radio"/>	3/8	14,5	11,5	12,8	22	25 g

Multiple Nozzle Base



Lechler GmbH
 Precision Nozzles - Droplet Separators
 P.O. Box 13 23
 72544 Metzingen / Germany
 Phone (0 71 23) 962-0
 Fax (0 71 23) 962-333
 E-mail: info@lechler.de
 Internet: www.lechler.de

Multiple Nozzle Base
order No. 600.130.56.05
 with 5 Whisperblast nozzles
 type 600.130.56.AC

Materials:
 Nozzles: POM, nozzle
 base: PVC

Thread: G 3/8" BSPP

Applications:

- Cover big working ranges
- Air curtain

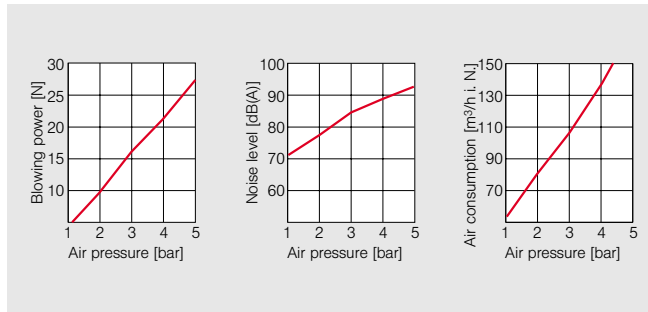

Multiple nozzle header
Order No. 600.326.41.04
 with 4 Whisperblast nozzles
 type 600.326.56.AC

Materials:
 Nozzles: POM
 Nozzle header: aluminium

Thread: 1/2" BSPP

Applications:

- Powerful blowing-out of excess of metal and water
- Clear tubes after cutting and washing processes
- ▶ **Up to 30 percent less air consumption in comparison to open tubes**

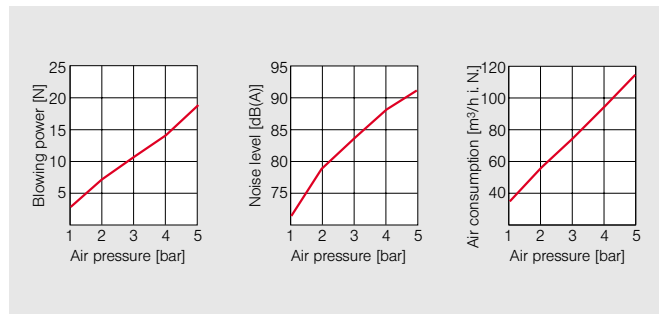

Lechler is also your partner for all liquid atomization applications.

Our new catalogue includes a wide range of products in an unsurpassed quality. Most of the products can be delivered immediately ex stock.

Please ask for it!

